

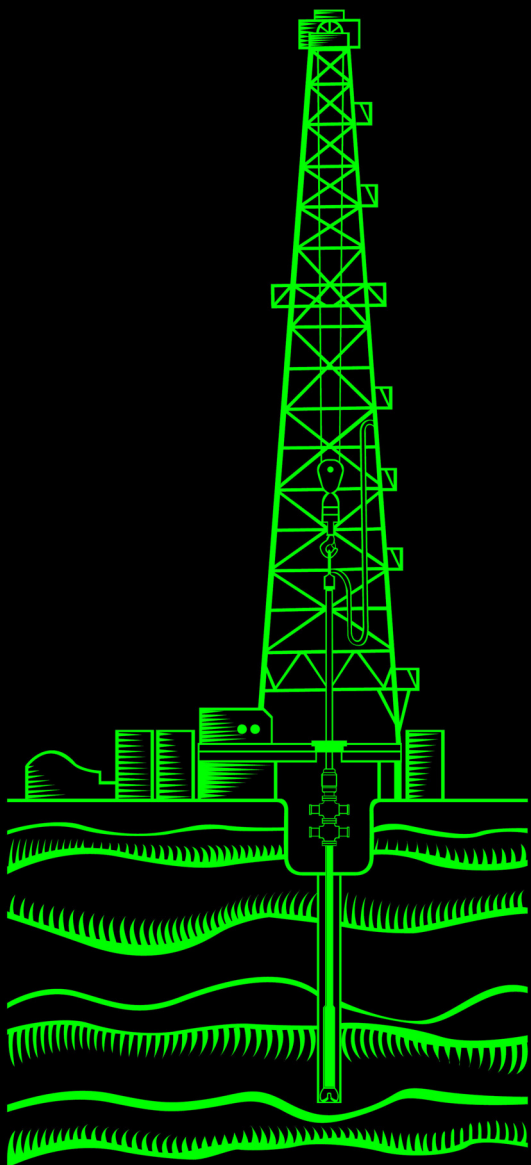

# **Toro Downhole Tools**



## **DRILLING TOOLS HANDBOOK**

**DRILLING JARS**

**SHOCK TOOLS**

**MOTOR  
OPTIMIZERS**





# DRILLING TOOLS HANDBOOK

— 2011 Edition —

This Drilling Tools Handbook is for informational purposes only. It is intended to be an aid to the Operator and is provided for information and illustration purposes only. Toro Downhole Tools (Toro) has taken every precaution as to the accuracy of the content and data presented herein, Toro makes no warranties, guarantees, or representations concerning the accuracy or the individual interpretation of the data presented. Further, Toro cannot be held responsible for any loss or damage to any property whatsoever; injury or death to any persons whatsoever; or any claims, demands, actions, complaints, proceedings, judgments, losses, damages, compensations, liabilities, costs or charges, however arising from the unauthorized or undirected use of this handbook or the data it contains.

Note: The technical data and information in this Drilling Tools Handbook is subject to change without notice.

**Toro Downhole Tools**  
16626 FM 2920  
Tomball, Texas 77377  
U.S.A.  
1-888-662-8676  
[www.torotools.com](http://www.torotools.com)

## TABLE OF CONTENTS

<b>Introduction .....</b>	<b>1</b>
<b>Tool Description.....</b>	<b>2</b>
Mechanical Jar (M).....	2
Hydraulic Jar (H) .....	3
Hydraulic–Mechanical Jar <i>single unit</i> (HM) .....	4
Hydraulic–Mechanical Jar <i>double unit</i> (HM2) .....	4
Shock Tool (SH) .....	6
Motor Optimizer (MO).....	7
<b>Tool Placement.....</b>	<b>8</b>
Drilling Jar Placement .....	8
Shock Tool Placement .....	10
Motor Optimizer Placement.....	10
<b>Tool Operation .....</b>	<b>11</b>
Drilling Jar Operation.....	11
Visual Inspection and Jar Prep.....	11
Maximum Operation Hours .....	11
Wall Friction (Wall Drag) .....	11
Free Drill String Weight.....	12
Pump Open Force .....	12
Jarring Up .....	12
Jarring Down .....	13
Adjusting the Jar Release Force .....	13
Laying Down .....	13
Shock Tool Operation.....	13
Visual Inspection and Shock Tool Prep .....	13
Maximum Operation Hours .....	14
Operation.....	14
Laying Down .....	14
Motor Optimizer Operation .....	14
Visual Inspection and Shock Tool Prep .....	14
Maximum Operation Hours .....	14
Operation.....	15
Laying Down .....	15

<b>Tool Specifications</b> .....	<b>15</b>
Tool Operational and Performance Disclaimer .....	15
Drilling Jar Parameters .....	16
Jar Piston Areas.....	16
Jar Pump Open Force.....	17
Drilling Jar Specifications .....	18
Shock Tool Specifications .....	22
Motor Optimizer Specifications.....	23
<b>Notes</b> .....	<b>24</b>

# INTRODUCTION

This handbook was written to help assist in providing effective solutions to your drilling challenges. This handbook covers the following Toro drilling tool products: Drilling Jars, Shock Tools, and Motor Optimizers. For information regarding Toro drilling motors, please refer to the Toro Drilling Motor Handbook.

The drilling jar is a mechanical or hydraulic device used downhole to deliver an impact load to another downhole component, especially when that component is stuck. Jars are usually classified as either drilling jars or fishing jars. The operation of the two types is similar, and both deliver approximately the same impact blow, but the drilling jar is built such that it can better withstand the rotary and vibration loading associated with drilling.

The shock tool (see Figure 1) is a hydraulic device designed to isolate the drill string from axial deflections produced by the bit during drilling operations. This reduces impact on the bit and drill string and increases penetration rates by keeping the bit on bottom during rough drilling conditions.

The motor optimizer is a hydraulic device used to isolate the drill string from motor vibration and motor reactive torque. Similar to the shock tool, the motor optimizer reduces impact on the drill bit but adds the ability to reduce the reactive torque of the drilling motor.

The downhole drilling jar, shock tool, and motor optimizer have undergone substantial changes and improvements over the past years making them a reliable tool even in the most rigorous of drilling environments. Today, most all drilling applications have become a planned routine operation. The technological advances in downhole drilling tools have helped to lower the cost of drilling a well. With the development of durable and reliable downhole tools, the odds of bringing in a successful well have been improved significantly from years past. The Toro Downhole Tools (Toro) line of drilling jars, shock tools, and motor optimizers are well suited for the drilling applications of today.

The primary focus of this handbook is to assist in explaining selection, positioning, and operations of these drilling tools. This handbook includes information on the following topics:

- ◆ Tool Description
- ◆ Tool Placement
- ◆ Tool Operation
- ◆ Tool Specifications

Note: Please read this handbook in its entirety. As always, the Toro technical staff is readily available to provide the information you may need regarding the operation of these drilling tools.

## TOOL DESCRIPTION

Figure 1  
Mechanical Jar

### *The Drilling Jar*

The drilling jar takes its energy from applied load in either the tension or compression of the drill string. Energy is stored up in the drill string in which the drilling jar releases this energy suddenly when tripped. The principle is similar to that of a carpenter using a hammer. Kinetic energy is stored in the hammer as it is swung, and suddenly released to the nail and board when the hammer strikes the nail. Jars can be designed to strike up, down, or both. In the case of jarring up above a stuck bottom hole assembly, the driller slowly pulls up on the drill string. The top of the drill string moves up but the BHA does not. This means that the drill string itself is stretching (in tension) and storing energy. When the jar reaches its firing point, an internal component of the jar rapidly moves axially relative to the drill string. This is similar to the way one end of a stretched spring moves when released. After a few inches of movement, this moving section slams into a steel shoulder, imparting an impact load.

There are four primary types of Toro drilling jars:

- ◆ Mechanical
- ◆ Hydraulic
- ◆ Hydraulic—Mechanical (single unit)
- ◆ Hydraulic—Mechanical (double unit)

While their respective designs are somewhat different from one another, their operation is similar.

### *Mechanical Jars*

The Toro mechanical jar is an integrated unit that provides both up and down jarring action. Figure 1 shows a cross-section view of the Toro mechanical (M) jar. Because it is an all mechanical jar, it is easy to operate, service, and maintain.

Some of the features the Toro mechanical jar include:

- ◆ Reduced length: up/down jarring integrated into one unit
- ◆ Simple and reliable design
- ◆ No safety clamps required
- ◆ No special handling procedures required on the rig floor
- ◆ Instantaneous jarring action without delay
- ◆ Ideal for use in high temperature applications



The Toro mechanical drilling jar relies on a trip and friction sleeve to activate. The jar is designed to fire when a sufficient amount of force (trip load) is applied to the jar in either up or down direction.

**Figure 2**  
**Hydraulic Jar**

To jar up, pull up on the drill string until reaching the trip load. The trip load will cause the internal spring unit to deform allowing the trip sleeve to engage the friction sleeve. When this happens, the mandrel is suddenly freed to release the jarring force. To reset the jar, remove the pull load by lowering the drill string.

To jar down, push down on the drill string until reaching the trip load. The load will cause the internal spring unit to deform allowing the trip sleeve to engage the friction sleeve. When this happens, the mandrel is suddenly freed to release the jarring force. To reset the jar, remove the downward load by pulling up on the drill string.

### *Hydraulic Jars*

The Toro Hydraulic jar is an integrated unit that provides both up and down jarring action using hydraulic fluid. Figure 2 shows a cross-section view of the Toro hydraulic (H) jar. The hydraulic jar includes a hydraulic delay action for both the up and down jarring. Some of the features the Toro hydraulic jar include:

- ◆ Reduced length: Up/down jarring integrated into one unit
- ◆ Hydraulic delay when jarring up and down
- ◆ Enclosed oil chambers for increase seal life
- ◆ Able to be used in elevated temperature applications
- ◆ Ideal for use in directional and horizontal drilling applications

Unlike the mechanical jar, the Toro hydraulic jar uses control valves to activate and thus does not rely on a mechanical friction sleeve. The hydraulic jar is designed to fire when a sufficient amount of force (trip load) is applied to the jar in either up or down direction.

To jar up, pull up on the drill string until reaching the trip load. The trip load will cause the hydraulic fluid to move through the control valves. When this happens, the mandrel is allowed to move into a hydraulic delay state. Once the mandrel reaches a certain distance, the hydraulic delay is removed allowing the mandrel to release the jarring force. To reset the jar, remove the upward load by lowering the drill string.

To jar down, push down on the drill string until reaching the trip load. The load will cause the hydraulic fluid to move through the control valves. When this happens, the mandrel is allowed to move into a hydraulic delay action. Once the mandrel reaches a certain

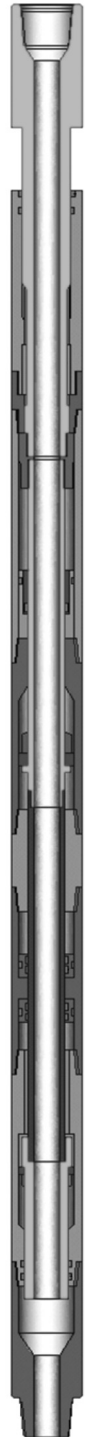

distance, the hydraulic delay is removed allowing the mandrel to release the jarring force. To reset the jar, remove the downward load by pulling up on the drill string.

**Figure 3**  
**Hydraulic—**  
**Mechanical Jar**  
**(single unit)**

### *Hydraulic—Mechanical Jars (single unit)*

The Toro Hydraulic—Mechanical jar (single unit) is a one piece jar that provides both up and down jarring action. Figure 3 shows a cross-section view of the Toro hydraulic—mechanical (HM) jar. The HM jar is based on the same design as the mechanical (HM) jar. The HM jar is based on the same design as the mechanical (HM) jar however it includes a hydraulic delay action on the up jarring. The Toro HM jar is designed to overcome the limitation of a pure mechanical or pure hydraulic jar by combining the properties of both. Some of the features the Toro HM jar include:

- ◆ Up/down jarring integrated into one unit
- ◆ No safety clamps required
- ◆ No special handling procedures required on the rig floor
- ◆ Hydraulic delay when jarring up
- ◆ Instantaneous action when jarring down
- ◆ Enclosed oil chambers for increase seal life
- ◆ Able to be used in elevated temperature applications
- ◆ Ideal for use in directional or horizontal drilling applications

The Toro HM jar is similar to the mechanical jar in that it relies on a trip and friction sleeve to activate. The jar is designed to fire when a sufficient amount of force (trip load) is applied to the jar in either up or down direction.

To jar up, pull up on the drill string until reaching the trip load. The trip load will cause the internal spring unit to deform allowing the trip sleeve to engage the friction sleeve. When this happens, the mandrel is allowed to move into a hydraulic delay action. Once the mandrel reaches a certain distance, the hydraulic delay is removed allowing the mandrel to release the jarring force. To reset the jar, remove the upward load by lowering the drill string.

To jar down, push down on the drill string until reaching the trip load. The load will cause the internal spring unit to deform allowing the trip sleeve to engage the friction sleeve. When this happens, the mandrel is suddenly freed release the jarring force. There is no hydraulic delay when jarring down. To reset the jar, remove the downward load by pulling up on the drill string.



## Hydraulic—Mechanical Jars (double unit)

The Toro Hydraulic—Mechanical jar (double unit) is a two piece jar that provides both up and down jarring action. Figure 4 shows a cross-section view of the Toro hydraulic—mechanical (HM2) jar. The HM2 jar is based on the same design as the HM except this jar is separated into an up jar and a down jar. The HM2 jar may be run as a single unit or may be installed as separate units at different locations within the drill string. Also, the two sections make it easy to transport and handle at the rig locations. The Toro HM2 jar is designed to overcome the limitation of a pure mechanical or pure hydraulic jar by combining the properties of both. Some of the features the Toro HM2 jar include:

- ◆ Two separate up/down jarring units
- ◆ Able to locate jarring units at different location within the drill string
- ◆ Can be used independently
- ◆ Hydraulic delay when jarring up
- ◆ Instantaneous action when jarring down
- ◆ Enclosed oil chambers for increase seal life
- ◆ Able to be used in elevated temperature applications
- ◆ Ideal for use in directional or horizontal drilling applications

The Toro HM2 jar is identical in operation to the single unit hydraulic—mechanical jar (HM).

To jar up, pull up on the drill string until reaching the trip load. The trip load will cause the internal spring unit to deform allowing the trip sleeve to engage the friction sleeve. When this happens, the mandrel is allowed to move into a hydraulic delay action. Once the mandrel reaches a certain distance, the hydraulic delay is removed allowing the mandrel to release the jarring force. To reset the jar, remove the upward load by lowering the drill string.

To jar down, push down on the drill string until reaching the trip load. The load will cause the internal spring unit to deform allowing the trip sleeve to engage the friction sleeve. When this happens, the mandrel is suddenly freed release the jarring force. There is no hydraulic delay when jarring down. To reset the jar, remove the downward load by pulling up on the drill string.

Figure 4  
Hydraulic—Mechanical Jar  
(double unit)

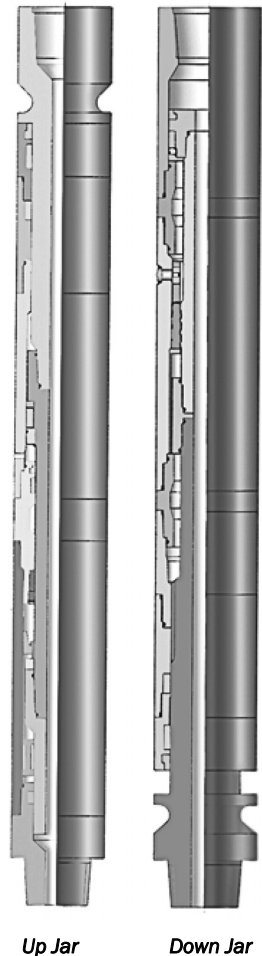

## The Shock Tool

Figure 4  
Hydraulic  
Shock Tool

The Toro Shock Tool (SH) is designed to provide maximum protection against BHA vibration damage while keeping the drill bit firmly on the bottom. Toro shock tools are engineered to reduce severe vibrations caused by hard formation drilling. By eliminating drill string bounce, the Toro Shock Tool helps to reduce drill string connection fatigue and prolong drill string life. Some of the features the Toro Shock Tool include:

- ◆ Full hydraulic design for maximum reliability.
- ◆ Reduced length
- ◆ Extends bit life by reducing impact loads and bit bounce
- ◆ Reduces shock and vibration induced drill string failures.
- ◆ Reduces damage to surface equipment.
- ◆ Unaffected by downhole pressure
- ◆ Simple and reliable design
- ◆ Suitable for use in elevated temperature applications

Toro Shock Tools feature a large inner diameter for high flow rates and for passing wire line or other equipment through the center bore. The Toro Shock Tools are hydraulic by design for maximum durability and reliability. The Toro Shock Tool features a male/female spline assembly encased by a hydraulic piston reservoir. Constant load/deflection characteristics are maintained regardless of hole depth, bit weight, pump pressure, mud weight, or torque. The shock tool incorporates a male spline mandrel interlocked with a female spline housing. This interlock allows for controlled vertical movement while transferring the rotational loads to the drill string. The Toro Shock Tools are fully sealed preventing the drilling fluid from contacting the internal mechanical components. Toro Shock Tools are available with a standard seal kit rated to 250 °F or an optional higher temperature seal kit rated at 350 °F.

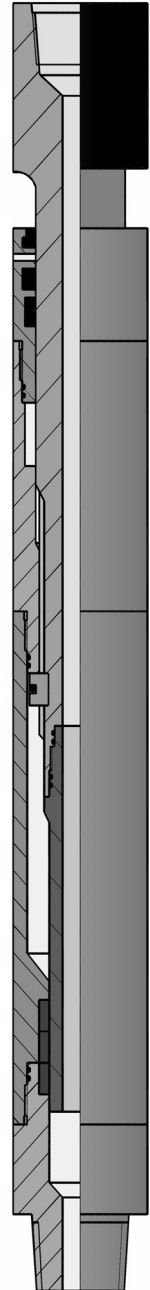

## The Motor Optimizer

The Toro Motor Optimizer (MO) is designed to get optimum power and torque from a downhole drilling motor. The Toro Motor Optimizer improves the rate of penetration (ROP) by controlling both the vertical and rotational reactive forces of the motor. The Motor Optimizer helps to improve drilling performance by maintaining the weight on bit (WOB) on the motor thus keeping the drill bit firmly on bottom. The Motor Optimizer will also extend the life of the downhole motor by helping to prevent the motor from being overworked. The Toro Motor Optimizers are hydraulic by design for maximum durability and reliability. Some of the features the Toro Motor Optimizer include:

- ◆ Controls downhole motor vertical reactive forces
- ◆ Controls downhole motor rotational reactive forces
- ◆ Optimizes the WOB applied to the motor
- ◆ Optimizes the rate of penetrations
- ◆ Helps to extend motor life
- ◆ Full hydraulic design for maximum reliability.
- ◆ Unaffected by downhole pressure
- ◆ Simple and reliable design
- ◆ Suitable for use in elevated temperature applications

Figure 5  
Motor  
Optimizer

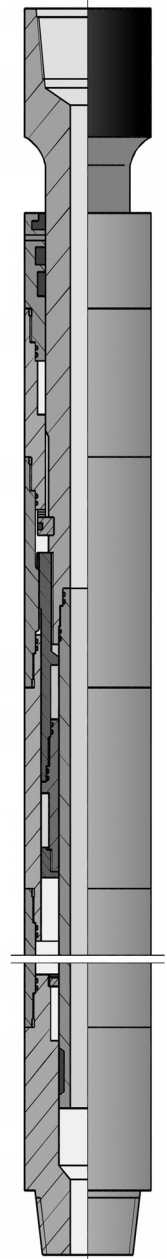

## **TOOL PLACEMENT**

### ***Drilling Jar Placement***

Determining the best location in the bottom hole assembly (BHA) for a drilling jar can be a challenging problem. There are several factors that have to be considered when placing the jar in the BHA. These include:

- ◆ Well type: vertical, directional, horizontal
- ◆ Bottom hole assembly
- ◆ Pump pressure
- ◆ Drill pipe strength and over-pull capability
- ◆ Weight on bit (WOB)
- ◆ Anticipated hole conditions
- ◆ Anticipating differential or mechanical sticking
- ◆ Load setting for the jar

Each drilling application can vary and the combination of drilling factors is unique. However below are some suggestions and recommendations for the placement of the jar for maximum effect.

- ◆ Whenever possible, try placing the drilling jar above an anticipated sticking point.
- ◆ Ensure that at least two drill collars or heavy weight drill pipe is run above and below the jar to provide sufficient mass for jarring.
- ◆ Avoid locating the jar near a crossover sub or between two BHA components with dissimilar outer diameters.
- ◆ If a shock tool is used in the drill string, then the jar should be placed above it.
- ◆ Locate the jar high the BHA in holes where differential sticking is expected to reduce the chance of sticking above the jar.
- ◆ Locate the jar low in the BHA in holes where mechanical sticking is expected to increase jarring efficiency.
- ◆ Keep at least two drill collars or heavy wall pipe between a jar and a stabilizer. Placing the jar too close to a stabilizer can induce severe bending stress within the jar. See Figure 6 for reference.

Figure 6 – String Placement of a Drilling Jar

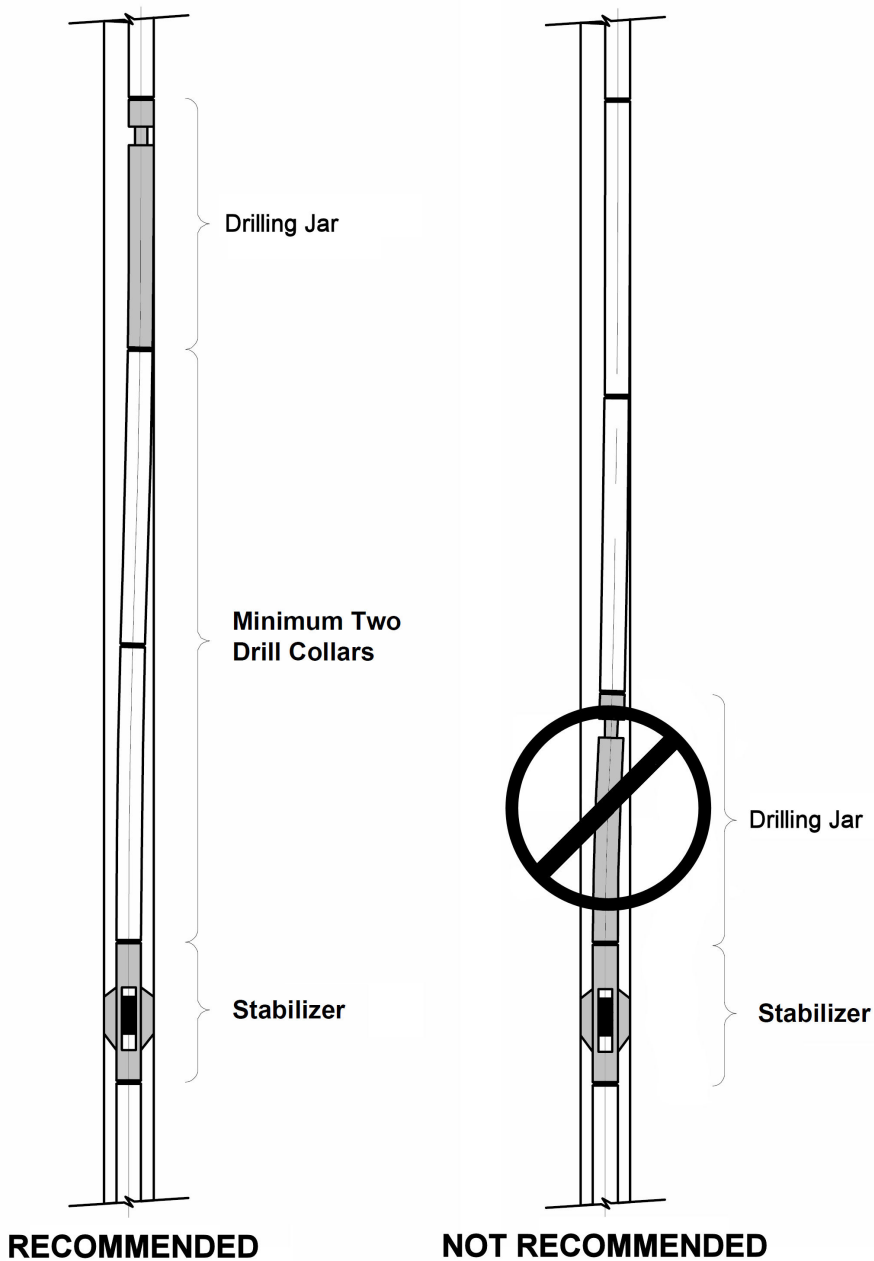

## ***Shock Tool Placement***

The location of the shock tool within the drill string varies depending on the application. However, it is important to keep at least two drill collars or heavy wall pipe between a shock tool and a stabilizer. Placing the shock tool too close to a stabilizer can induce severe bending stress within the shock tool. See Figure 5 regarding the drilling jar placement for reference. In some applications, the shock tool is installed just above the drill bit to minimize the BHA vibration. If a drilling motor is used, then the shock tool can be installed immediately above the motor.

## ***Motor Optimizer Placement***

The location of the Motor Optimizer within the drill string varies depending on the application.

For vertical (straight hole) drilling applications, it is recommended to place the Motor Optimizer directly above the drilling motor.

For directional applications or applications where a Measure-While-Drilling (MWD) tool is being used, it is highly recommended that the Motor Optimizer be placed above the MWD measuring tool. Placing the Motor Optimizer below a MWD or other measuring tool can lead to false tool face (high side) readings. It is important to remember that the Motor Optimizer adjusts radially to counteract the motor reactive torque loads. Placing the Motor Optimizer above the MWD keeps the high side of the drilling motor aligned with the MWD.

When using stabilizers within the drill string, it is important to keep at least two drill collars or heavy wall pipe between a Motor Optimizer and a stabilizer. Placing the Motor Optimizer too close to a stabilizer can induce severe bending stress within the tool. See Figure 5 for drilling jar placement as a reference.

## **TOOL OPERATION**

Operators, drilling contractors, service, and tool supply companies have worked diligently over the years to improve drilling technology. Their common goal has been to reach their drilling targets, quickly, efficiently, and at a reasonable cost. Over the years, these drilling targets have become more complex and difficult to reach. The operation of the tools is important to ensure that hole is successful drilled. This section of the manual covers the operation of the drilling jar and shock tool in the drill string.

### ***Drilling Jar Operation***

#### ***Visual Inspection and Jar Prep***

Before installing a jar in the drill string, the threads need to thoroughly cleaned with a solvent to remove any grease, pipe dope, or other coatings protecting the threads. Ensure that the tool bore is clear of all debris and that the jar is in its neutral (non-fired) state. Before each trip, the drilling jar should be visually inspected for indications of damage such as diametrical wear, grooves in the mandrel, hydraulic oil leakage, or other excessive wear. Do not use the jar if there is any damage to the tool or threaded connections.

#### ***Maximum Operating Hours***

It is important to know how many operational hours the jar will be used. Toro recommends that a drilling jar not exceed 400 or more operational hours before being serviced and inspected. The jar should always be serviced after any heavy jarring usage or after long periods of continuous jarring. For high temperature applications or applications where the drilling fluid contains corrosive additives, it is recommended that the jar not exceed 200 hours of operational use before being serviced.

#### ***Wall Friction (Wall Drag)***

Wall friction is the force generated between the drill string and the wall of the bore hole. The wall friction can vary greatly, especially for deviated holes and horizontal wells. When calculating the force required to fire a jar, it is important to compensate for wall friction. The drill string wall friction can easily be determined from the weight indicator readings during tripping.

## Free Drill String Weight

The free drill string weight is the weight of the drill string above the tool. To calculate the free drill string weight, take the weight of the drill string below the jar and subtract it from the total drill string weight.

## Pump open Force

Pump-open force is the force exerting on the jar from the mud pressure in the drill string. If the mud pressure is high enough, it can cause the jar to extend. Therefore, it is important to consider the pump-open force when determining the force to required to jar up or down. The pump-open force is calculated by multiplying the pressure drop across the bit (bit pressure drop) by the piston area. The pump open areas for each jar are listed in the *Tool Specifications* section of this manual.

To calculate the pump-open force for a 6-1/2" Mechanical jar with 1,000 psi bit pressure drop:

$$\text{Pump-open Force} = (1000 \text{ lb/in}^2) \times (15.50 \text{ in}^2) = 15,500 \text{ lbs}$$

## Jarring Up

To jar up, pull upward on the drill string until the reaching the *Jar Up Hook Load*. The *Jar Up Hook Load* is calculated as follows:

$$\text{Jar Up Hook Load} = (\text{Free drill string weight}) + (\text{Jar up release load}) \\ + (\text{Wall friction}) - (\text{Pump-open force})$$

*For Mechanical Jars:* The jar will fire once the hook load is reached.

*For Hydro-Mech. Jars:* The jar will enter the hydraulic delay sequence once the hook load is reached. After about 30 seconds (or about 6 inches of upward drill string travel), the jar will fire.

*For Hydraulic Jars:* The jar will enter the hydraulic delay sequence once the hook load is reached. After about 30 seconds (or about 6 inches of upward drill string travel), the jar will fire.

To reset the jar, lower the drill string until the hook load is less than the free drill string weight. To jar up again, repeat the above steps.

## *Jarring Down*

To jar down, lower the drill string (slack off) until the reaching the *Jar Down Hook Load*. The *Jar Down Hook Load* is calculated as follows:

$$\text{Jar Down Hook Load} = (\text{Free drill string weight}) - (\text{Jar down release load}) \\ - (\text{Wall friction}) - (\text{Pump-open force})$$

*For Mechanical Jars:* The jar will fire once the hook load is reached.

*For Hydro-Mech. Jars:* The jar will fire once the hook load is reached.

*For Hydraulic Jars:* The jar will enter the hydraulic delay sequence once the hook load is reached. After about 30 seconds (or about 6 inches of downward drill string travel), the jar will fire.

To reset the jar, pull up on the drill string until the hook load is greater than the free drill string weight. To jar down again, just repeat the above steps.

## *Adjusting the Jar Release Force*

All up and down release forces are set at the time the jar is assembled. There are no field adjustments with the drilling jar.

## *Laying Down*

After use, the jar should be thoroughly flushed inside and out with fresh water. Reinstall the thread protectors to prevent damage to the end connections. Tools should be stored horizontally and rotated periodically to prevent the seals from setting resulting in hydraulic fluid leakage.

## ***Shock Tool Operation***

### *Visual Inspection and Shock Tool Prep*

New and refurbished tools are shipped painted and identified. Thread protectors are installed to prevent damage to the threaded connection. Before installing a shock tool in the drill string, the threads need to be thoroughly cleaned with a solvent to remove any grease, pipe dope, or other coatings protecting the threads. Ensure that the tool bore is clear of all debris. Before each trip, the shock tool should be visually inspected for indications of damage such as diametrical wear, grooves in the mandrel, hydraulic oil leakage, or other excessive wear. Do not use the shock tool if there is any damage to the tool or threaded connections.

## *Maximum Operating Hours*

It is important to know how many operational hours the shock tool will be used. Toro recommends that a shock tool not exceed 400 or more operational hours before being serviced and inspected. For high temperature applications or applications where the drilling fluid contains corrosive additives, it is recommended that the shock tool not exceed 200 hours of operational use before being serviced.

## *Operation*

The shock tool operates continuously so there is no activation like with a drilling jar. Constant load/deflection characteristics are maintained regardless of hole depth, bit weight, pump pressure, mud weight, or torque. There is no field adjustment with the shock tool.

## *Laying Down*

After use, the shock tool should be thoroughly flushed inside and out with fresh water. Reinstall the thread protectors to prevent damage to the end connections. Tools should be stored horizontally and rotated periodically to prevent the seals from setting resulting in hydraulic fluid leakage.

## *Motor Optimizer Operation*

### *Visual Inspection and Motor Optimizer Prep*

New and refurbished tools are shipped painted and identified. Thread protectors are installed to prevent damage to the threaded connection. Before installing a motor optimizer in the drill string, the threads need to be thoroughly cleaned with a solvent to remove any grease, pipe dope, or other coatings protecting the threads. Ensure that the tool bore is clear of all debris. Before each trip, the motor optimizer tool should be visually inspected for indications of damage such as diametrical wear, grooves in the mandrel, hydraulic oil leakage, or other excessive wear. Do not use the motor optimizer if there is any damage to the tool or threaded connections.

## *Maximum Operating Hours*

It is important to know how many operational hours the motor optimizer will be used. Toro recommends that a motor optimizer not exceed 400 or more operational hours before being serviced and inspected. For high temperature applications or applications where the drilling fluid contains corrosive additives, it is recommended that the motor optimizer not exceed 200 hours of operational use before being serviced.

## *Operation*

The motor optimizer operates continuously so there is no activation like with a drilling jar. Constant load/deflection characteristics are maintained regardless of hole depth, bit weight, pump pressure, mud weight, or torque. There is no field adjustment with the motor optimizer.

## *Laying Down*

After use, the motor optimizer should be thoroughly flushed inside and out with fresh water. Reinstall the thread protectors to prevent damage to the end connections. Tools should be stored horizontally and rotated periodically to prevent the seals from setting resulting in hydraulic fluid leakage.

## **TOOL SPECIFICATIONS**

Toro offers a wide range of drilling jars, shock tools and motor optimizers. Typically, these tools are categorized by the size of the outer diameter. For each size, there are several configurations available to meet a wide range of drilling applications. This part of the handbook is intended to provide the technical specifications and information for each tool.

## ***Tool Operation and Performance Disclaimer***

Toro Downhole Tools has taken every precaution as to the accuracy of the content and data presented in this section. Toro makes no warranties, guarantees, or representations concerning the accuracy or individual interpretation of the data. For the latest information regarding tool operation and performance, it is recommended that the nearest Toro representative be contacted.

## Drilling Jar Parameters

### Jar Piston Areas

<b>Drilling Jar Models</b>	M-625	M-650	M-700	M-800
<b>Piston Area (in<sup>2</sup>)</b>	15.50	15.50	20.62	27.28

<b>Drilling Jar Models</b>	H-475	H-650	H-675	H-700	H-800	H-950
<b>Piston Area (in<sup>2</sup>)</b>	3.60	5.17	5.75	6.00	9.00	10.00

<b>Drilling Jar Models</b>	HM-475	HM-650	HM-800
<b>Piston Area (in<sup>2</sup>)</b>	9.30	15.50	27.28

## Jar Pump Open Force

Drilling Jar Models		M-475	M-650	M-700	M-800
Pump Open Force (lbs)	@ 1,000 psi bit pressure drop	15,500	15,500	20,620	27,280
	@ 1,500 psi bit pressure drop	23,250	23,250	30,930	40,920
	@ 2,000 psi bit pressure drop	31,000	31,000	41,240	54,560
	@ 2,500 psi bit pressure drop	38,750	38,750	51,550	68,200
	@ 3,000 psi bit pressure drop	46,500	46,500	61,860	81,840

Drilling Jar Models		H-475	H-650	H-675	H-700	H-800	H-950
Pump Open Force (lbs)	@ 1,000 psi bit pressure drop	3,600	5,170	5,750	6,000	9,000	10,000
	@ 1,500 psi bit pressure drop	5,400	7,755	8,625	9,000	13,500	15,000
	@ 2,000 psi bit pressure drop	7,200	10,340	11,500	12,000	18,000	20,000
	@ 2,500 psi bit pressure drop	9,000	12,925	14,375	15,000	22,500	25,000
	@ 3,000 psi bit pressure drop	10,800	15,510	17,250	18,000	27,000	30,000

Drilling Jar Models		HM-475	HM-650	HM-800
Pump Open Force (lbs)	@ 1,000 psi bit pressure drop	9,300	15,500	27,280
	@ 1,500 psi bit pressure drop	13,950	23,250	40,920
	@ 2,000 psi bit pressure drop	18,600	31,000	54,560
	@ 2,500 psi bit pressure drop	23,250	38,750	68,200
	@ 3,000 psi bit pressure drop	27,900	46,500	81,840

# Drilling Jar Specifications

## Model M – Mechanical Drilling Jar Specifications

Drilling Jar Model		M-625	M-650	M-700	M-800
Drilling Jar Type		Full Mechanical	Full Mechanical	Full Mechanical	Full Mechanical
OD (in)		6 1/4	6 1/2	7.0	8.0
ID (in)		2 1/4	2 1/4	2 1/4	2 3/4
Length (ft)		34.2	34.2	33.4	34.0
Weight (lbs)		2,535	2,734	2,976	3,924
Standard Connections		4-1/2 IF NC 50	4-1/2 IF NC 50	4-1/2 IF NC 50	6-5/8 REG
Total Stroke	Up (in)	5.6	5.6	5.9	5.7
	Down (in)	6.8	6.8	6.6	7.0
Max. Release Load ( $\pm 15\%$ )	Up (lbs)	139,382	139,382	141,630	179,847
	Down (lbs)	80,931	80,931	80,931	101,164
Max. Pull Load (lbs)		494,580	494,580	494,580	562,022
Max. Torsional Load (lbs-ft)		11,063	11,063	11,063	14,751

**Model H – Hydraulic Drilling Jar Specifications**

<b>Drilling Jar Model</b>		<b>H-475</b>	<b>H-650</b>	<b>H-675</b>	<b>H-700</b>	<b>H-800</b>	<b>H-900</b>	<b>H-950</b>
<b>Drilling Jar Type</b>		Full Hydraulic	Full Hydraulic	Full Hydraulic	Full Hydraulic	Full Hydraulic	Full Hydraulic	Full Hydraulic
<b>OD (in)</b>		4 3/4	6 1/2	6 3/4	7.0	8.0	9.0	9 1/2
<b>ID (in)</b>		2.0	2 3/4	2 3/4	3.0	3.0	3.0	3 1/4
<b>Length (ft)</b>		31.0	31.0	31.0	31.0	34.5	34.5	34.5
<b>Weight (lbs)</b>		1,235	2,800	2,943	3,876	4,608	6,195	6,415
<b>Standard Connections</b>		3-1/2 IF NC 38	4-1/2 IF NC 50	4-1/2 IF NC 50	4-1/2 IF NC 50	6-5/8 REG	7-5/8 REG	7-5/8 REG
<b>Total Stroke</b>	<b>Up (in)</b>	5.5	7.5	7.5	7.5	7.5	7.5	7.5
	<b>Down (in)</b>	7.0	7.5	7.5	7.5	7.5	7.5	7.5
<b>Max. Release Load (± 15%)</b>	<b>Up (lbs)</b>	58,450	89,924	89,924	89,924	89,924	89,924	89,924
	<b>Down (lbs)</b>	38,218	49,458	49,458	49,458	49,458	49,458	49,458
<b>Max. Pull Load (lbs)</b>		449,618	899,236	899,236	899,236	1,573,663	1,978,319	1,978,319
<b>Max. Torsional Load (lbs-ft)</b>		20,652	59,005	59,005	118,010	162,263	184,390	184,390
<b>Time Delay (sec)</b>		40 - 180	40 - 180	40 - 180	40 - 180	40 - 180	40 - 180	40 - 180

**Model HM – Hydraulic-Mechanical (One-Piece) Drilling Jar Specifications**

Drilling Jar Model		HM-475	HM-650	HM-675	HM-800	HM-900
Drilling Jar Type		Hydraulic Mechanical	Hydraulic Mechanical	Hydraulic Mechanical	Hydraulic Mechanical	Hydraulic Mechanical
OD (in)		4 3/4	6 1/2	6 3/4	8.0	9.0
ID (in)		2.0	2 1/4	2 1/4	2 3/4	3.0
Length (ft)		14.8	17.0	17.0	18.9	20.1
Weight (lbs)		631	1,407	1,764	2,511	3,532
Standard Connections		3-1/2 IF NC 38	4-1/2 IF NC 50	4-1/2 IF NC 50	6-5/8 REG	7-5/8 REG
Total Stroke	Up (in)	9.0	8.8	8.8	9.5	12.0
	Down (in)	5.9	5.9	5.9	6.9	6.2
Max. Release Load (± 15% )	Up (lbs)	85,120	161,280	161,280	244,160	212,800
	Down (lbs)	56,202	112,404	112,404	134,885	146,126
Max. Pull Load (lbs)		314,733	494,580	494,580	809,312	944,198
Max. Torsional Load (lbs-ft)		9,588	11,063	11,063	14,751	16,226

**Model HM2 – Hydraulic-Mechanical (Two-Piece) Drilling Jar Specifications**

Drilling Jar Model		HM2-475	HM2-575	HM2-625	HM2-650	HM2-700	HM2-775	HM2-800	HM2-900
Drilling Jar Type		Hydraulic Mechanical	Hydraulic Mechanical	Hydraulic Mechanical	Hydraulic Mechanical	Hydraulic Mechanical	Hydraulic Mechanical	Hydraulic Mechanical	Hydraulic Mechanical
OD (in)		4 3/4	5 3/4	6 2/7	6 1/2	7.0	7 3/4	8.0	9.0
ID (in)		1 3/4	2 1/4	2 1/4	2 1/4	2 3/4	2 3/4	2 3/4	3.0
Section Length	Upper (ft.)	17.4	18.8	17.6	17.6	17.8	18.1	18.1	17.9
	Lower (ft.)	15.6	16.4	17.1	17.1	17.1	17.2	17.2	18.2
Weight (lbs)		1,433	1,918	2,403	2,646	2,976	4,299	4,683	5,732
Standard Connections		3-1/2 IF NC 38	4 -1/2 FH	4 IF NC 46	4 IF NC 46	4-1/2 IF NC 50	6-5/8 REG	6-5/8 REG	7-5/8 REG
Total Stroke	Up (in)	12.0	13.1	13.6	13.6	13.6	14.5	14.5	9.5
	Down (in)	7.0	7.1	7.0	7.0	7.0	7.0	7.0	10.0
Max. Release Load (± 15%)	Up (lbs)	60,698	101,164	123,645	123,645	123,645	168,607	168,607	224,809
	Down (lbs)	56,202	89,924	112,404	112,404	123,645	134,885	134,885	146,126
Max. Pull Load (lbs)		314,733	449,618	494,580	494,580	517,061	562,022	562,022	629,465
Max. Torsional Load (lbs-ft)		9,588	11,063	11,063	11,063	11,063	13,276	14,751	16,226

## Shock Tool Specifications

### Model SH – Shock Tool Specifications

Shock Sub Model	SH-475	SH-625	SH-650	SH-700	SH-800	SH-900	SH-950
Shock Sub Type	Hydraulic	Hydraulic	Hydraulic	Hydraulic	Hydraulic	Hydraulic	Hydraulic
OD (in)	4 3/4	6 1/4	6 1/2	7.0	8.0	9.0	9 1/2
ID (in)	1 1/2	1 3/4	1 3/4	2 1/4	2 1/2	2 3/4	2 3/4
Length (ft)	13.0	13.5	13.5	12.5	13.5	12.5	12.5
Weight (lbs)	617	882	1,058	1,235	1,631	2,161	2,425
Standard Connection	3-1/2 IF NC 38	4 IF NC 46	4 IF NC 46	4-1/2 IF NC 50	6-5/8 REG	7-5/8 REG	7-5/8 REG
Maximum Compression Load (lbs)	59,574	77,109	77,109	88,125	110,156	121,397	121,397
Maximum Pull to Yield (lbs)	224,809	337,213	337,213	337,213	449,618	449,618	449,618

# Motor Optimizer Specifications

Model MO – Motor Optimizer Specifications

Optimizer Model	MO-475	MO-625	MO-650	MO-700	MO-800	MO-900	MO-950
OD (in)	4-3/4	6-1/4	6-1/2	7-0	8-0	9-0	9-1/2
ID (in)	1-1/2	1-7/8	1-7/8	2-1/4	2-1/2	2-3/4	2-3/4
Length (ft)	14.8	17.0	17.0	18.4	18.1	18.0	18.0
Weight (lbs)	705	1,213	1,323	1,543	2,205	2,866	3,307
Standard Connection	3-1/2 IF NC38	4 IF NC46	4 IF NC46	4-1/2 IF NC50	6-5/8 REG	7-5/8 REG	7-5/8 REG
Maximum WOB Load (lb)	45,000	76,000	76,000	90,000	108,000	121,000	121,000
Maximum Torque Load (ft-lb)	7,400	11,000	11,000	11,000	15,000	15,000	15,000
Maximum Pull to Yield (lb)	224,800	337,200	337,200	337,200	440,000	440,000	440,000





**Toro Downhole Tools**

16626 FM 2920

Tomball, Texas 77377

U.S.A.

1-888-662-8676

[Www.torotools.com](http://www.torotools.com)